

◆◆ Aristocrat™

- 2 1/4 wide solid oak (milled from 5/4 oak) frame molding
- Frame molding stained and finished using a 5-stage process
- Available in Light Oak Stain, Medium Oak Stain, Dark Oak Stain, Red Mahogany Stain, Whitewash, Clear Lacquer and Unfinished*
- Matching oak fascia pre-attached to Top Channel
- All frame molding hand-sanded for a custom quality finish
- Mitered corners
- All corners glued and secured by two tapered corner fasteners
- 3 mm float plate mirror
- 1 Bevel All available
- Full 1 adjustment to fit opening height, +/- 1/2
- 1 1/2 diameter wheels with hardened steel races and 5/32 ball bearings in extra-heavy 18-gauge steel housing
- Injection molded top guides for smooth operation
- Heavy-duty Champagne Gold painted steel Top Channel and Bottom Track standard with all Oak stain finishes except Whitewash which is supplied with Gloss White Top Channel and Bottom Track
- Gold or Silver Mylar trim available (see Golden Oak™, page 69)
- Matching framed wall mirrors available
- Standard and custom sizes available
- Standard opening width: 48 , 60 , 72 , 84 , 96 , 108 , 120 , 144 , 168 , 192
- Standard opening height 81 and 96 , +/- 1/2

* Unfinished not guaranteed against warpage

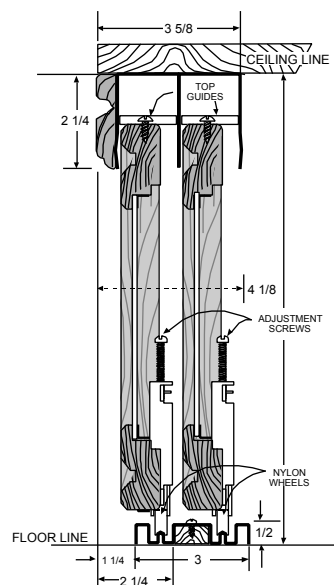

Aristocrat™