

◇◇ *Aurora*™

- Heavy gauge #6063 aluminum extrusions (#6463 “Polished” for Bright colors)
- Available in Bright Clear (Silver), Bright Gold (polished brass look) with an R-5 Bright Dip finish and Satin Clear, Satin Gold or Dark Bronze Anodized or Hi-Gloss White Paint
- 3 mm float plate mirror
- Top Channel and Bottom Track are extruded aluminum finished to match
- Bottom rolled with jump-proof tracks
- Mitered corners
- One-piece hand-glazed vinyl, color-coordinated to match frame
- Injection molded top guides for smooth operation
- 1 1/2 diameter wheels with hardened steel races and 5/32 ball bearings in extra-heavy 18-gauge steel housing
- Full 1 adjustment to fit opening height
- Standard and custom sizes available
- Standard opening width: 48 , 60 , 72 , 84 , 96 , 108 , 120 , 144 , 168 , 192
- Standard opening height: 81 and 96 , +/- 1/2

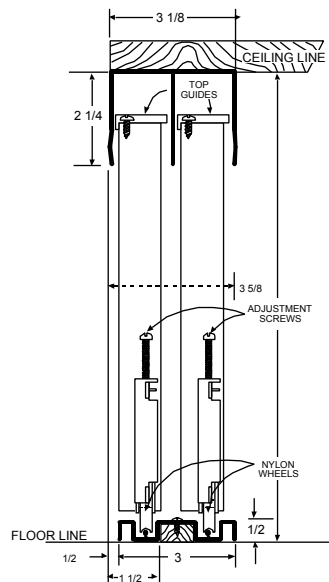

*Aurora*™